



Product Installation Guidelines

CliniLever[®] Lead Safe[™] Hospital Swivel Wall Outlets

PRODUCT CODES:

- 102.51.01.00 - 102.51.11.00 - 102.51.21.00
- 102.52.01.00 - 102.52.11.00 - 102.52.21.00

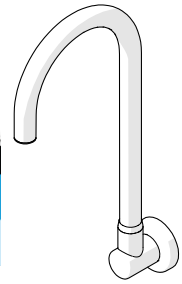

SPECIFICATIONS

- The Clinilever[®] product range is primarily used for hand washing applications in medical facilities, hospitals, aged care facilities, schools, and in-home care.
- Clinilever[®] products provide state of the art features to comply with the latest healthcare guidelines.
- Convenient swivel design.
- Robust construction for long life.
- Low maintenance.
- Laminar flow.
- Finished in bright chrome plate for easy cleaning and durability.
- Lead Safe[™] brass construction. *

IMPORTANT: All Clinilever[®] healthcare taps are tested in accordance with AS/NZS 3718 and leave our premises in good working order.

*As 'lead free' is not currently defined by law in Australia and New Zealand, we have based our definition of Lead Safe[™] on the requirements of Sec 1417 of the USA's Safe Drinking Water Act (SDWA) and the relevant US standards NSF61 / NSF372. The SDWA defines 'lead free' as "not more than a weighted average of 0.25% lead when used with respect to the wetted surface of pipes, pipe fittings, plumbing fittings, and fixtures".

WARNINGS: Special attention to be paid to notes, photos, images, or drawings of assembly steps marked with the warning symbol.



TECHNICAL DATA

Inlet	1/2" BSP - Female	
Outlet	Laminar Flow	
Headwork	N/A	
Working Pressure Range (kPa)	Min	50
	Max	500
Working Temperature Range (°C)	Min	5
	Max	65
Nominal Flow Rate (LPM)		
102.51.01.00/ 102.51.21.00	5.22	
102.52.01.00	5.08	
102.51.11.00	5.22	
102.52.11.00	5.60	
102.52.21.00	5.15	
Finish	Chrome	

NOTE: Galvin Engineering continually strive to improve their products. Specifications may change without notice.

TOOLS REQUIRED

- Spanner or adjustable crescent
- Thread tape

PRE-INSTALLATION

MOUNTING DETAILS

Wall Spud – Wall spud must be 1/2" BSP MI and protrude from the finished wall by no more than 15mm.

Note: In some situations, a male thread connection on the tap may be more suited. If so, please contact us on 1300 514 074

Note: Before installation, all lines must be flushed. We recommend that a line strainer be installed prior to taps to eliminate any foreign material.

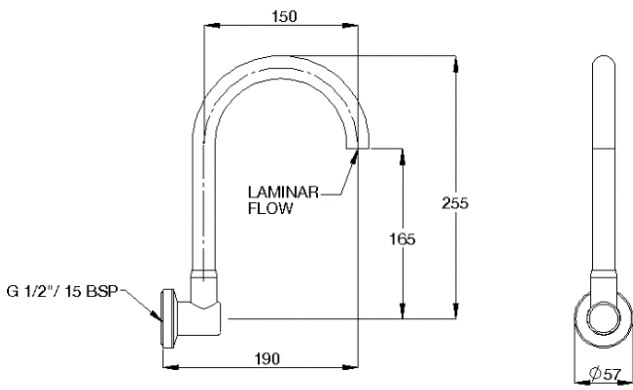
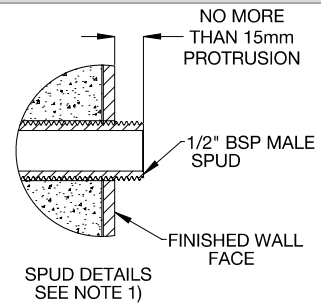

102.51.01.00

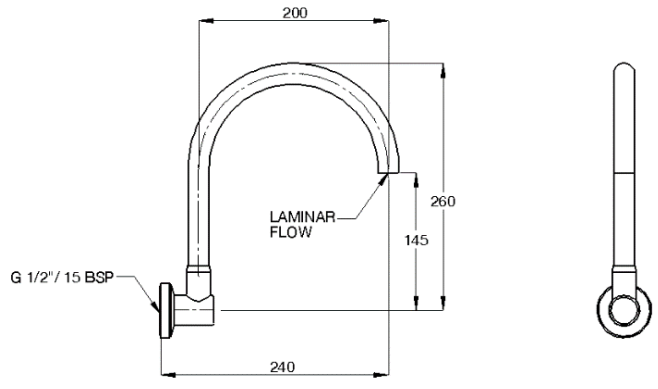

102.51.11.00

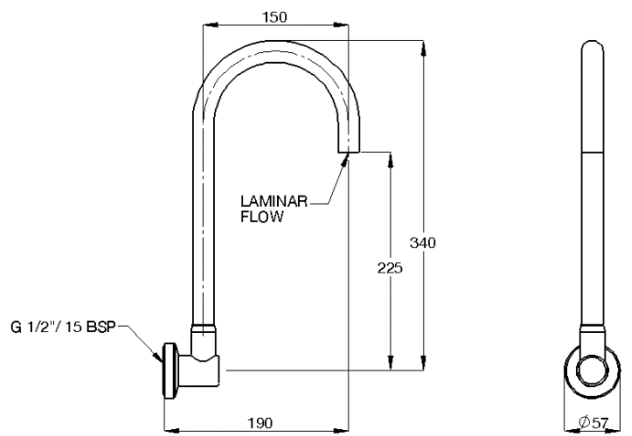

102.51.21.00

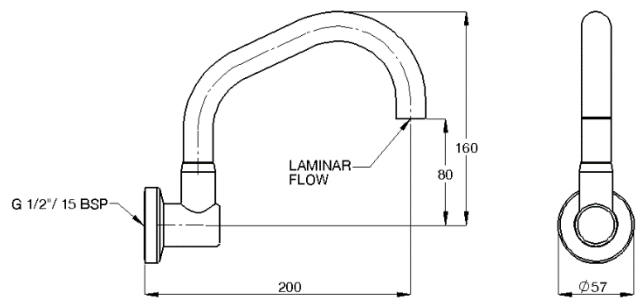

102.52.01.00

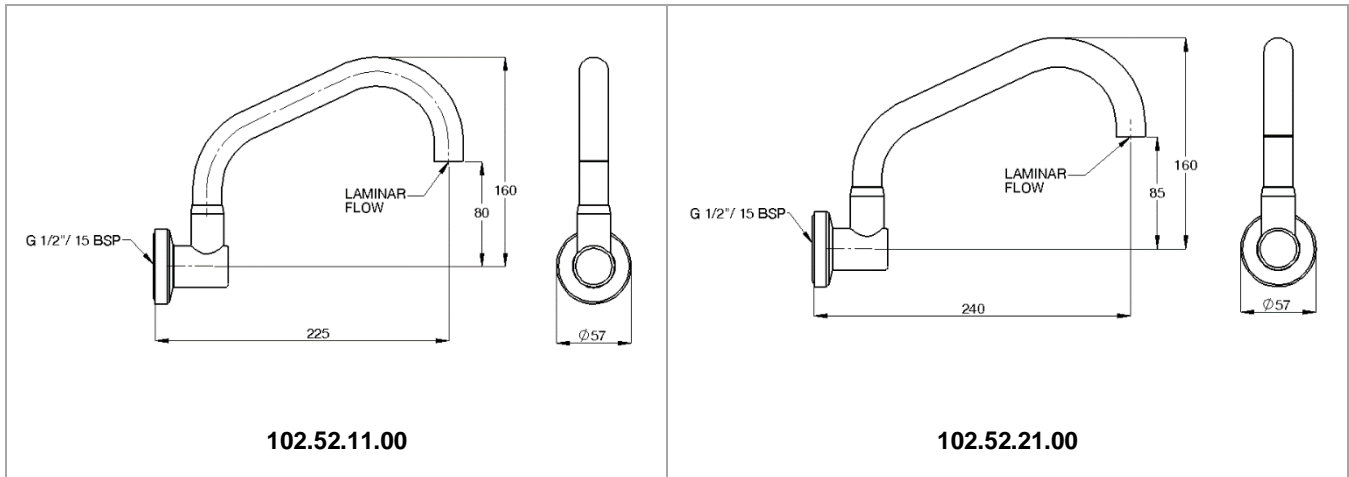

INSTALLATION

IMPORTANT: Galvin Engineering products must be installed in accordance with these installation instructions and in accordance with AS/NZS 3500, the PCA and your local regulatory requirements. Water and/or electrical supply conditions must also comply to the applicable national and/or state standards. Failing to comply with these provisions shall void the product warranty and may affect the performance of the product.

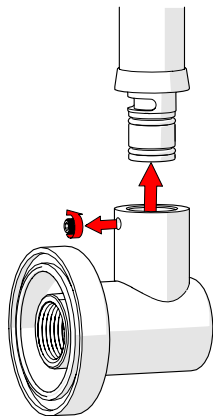

1. Fit tap assembly

- Remove the spout from the wall elbow using a hex key. This is to enable easy installation and prevent the spout being damaged.

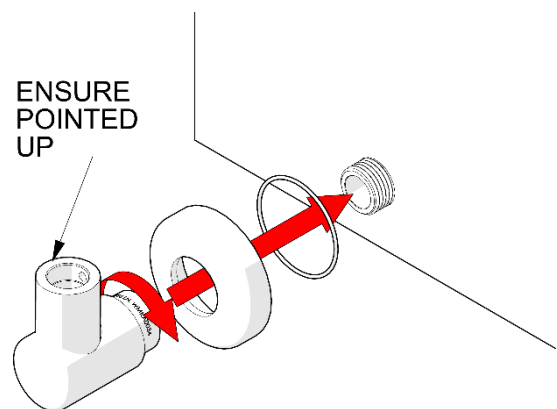

2. Connect

- Place the wall flange over the elbow. Fit the elbow to the protruding wall spud. We recommend using thread tape or an equivalent to ensure the connection does not leak.
- Ensure spout connection is pointing up (vertical).

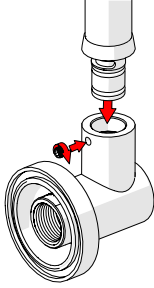
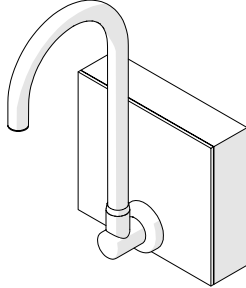
	
<p>3. Refit the spout</p> <ul style="list-style-type: none"> – Refit the spout to the elbow. Tighten the grub screw using a hex key. <p>Note: Do not overtighten grub screw. ⚠️ Ensure spout swivels freely once installed.</p>	<p>4. Testing</p> <ul style="list-style-type: none"> – Turn on the water supply and test for leaks.

TROUBLESHOOTING		
PROBLEM	CAUSE	RECTIFICATION
Inconsistent flow	Blocked aerator	Remove aerator and clean
	Blocked top assembly	Remove top assembly and clean
Water is not flowing from the tap	Water is turned off	Turn on the water
Continuous flow	Top assembly loose or internally obstructed or damaged	Remove top assembly, clean with water, and replace if required

WARRANTY
<p>The warranty set forth herein is given expressly and is the only warranty given by the Galvin Engineering Pty Ltd. With respect to the product, Galvin Engineering Pty Ltd makes no other warranties, express or implied. Galvin Engineering Pty. Ltd. hereby specifically disclaims all other warranties, express or implied, including but not limited to the implied warranties of merchantability and fitness for a particular purpose.</p>
<p>Galvin Engineering Pty Ltd products are covered under our manufacturer’s warranty available for download from www.galvinengineering.com.au Galvin Engineering Pty Ltd expressly warrants that the product is free from operational defects in workmanship and materials for the warranty period as shown on the schedule in the manufacturer’s warranty. During the warranty period, Galvin Engineering will replace or repair any defective products manufactured by Galvin Engineering without charge, so long as the terms of the Manufacturer’s warranty are complied with.</p>
<p>The remedy described in the first paragraph of this warranty shall constitute the sole and exclusive remedy for breach of warranty, and Galvin Engineering Pty Ltd shall not be responsible for any incidental, special or consequential damages, including without limitation, lost profits or the cost of repairing or replacing other property which is damaged if this product does not work properly, other costs resulting from labour charges, delays, vandalism, negligence, fouling caused by foreign material, damage from adverse water conditions, chemical, electrical or any other circumstances over which Galvin Engineering has no control. This warranty shall be invalidated by any abuse, misuse, misapplication, improper installation or improper maintenance or alteration of the product.</p>